

# SimplyShade™

## **Bali Pro** *Starlight Cantilever*

10' Square / SSAD45SL-10SQ

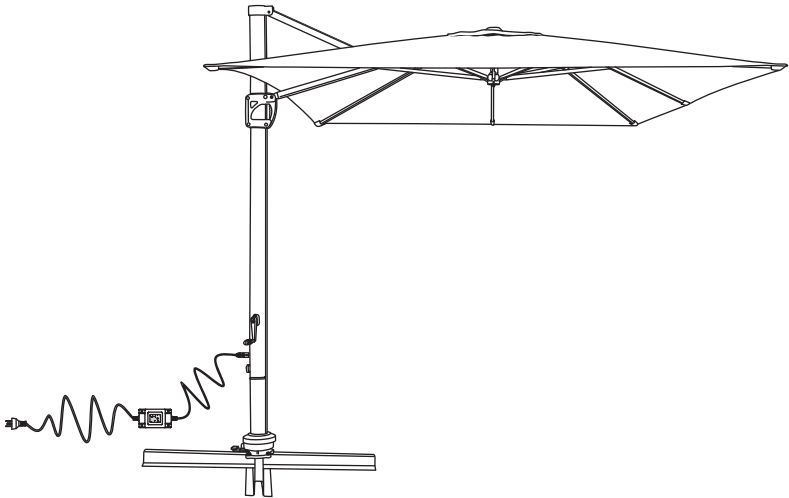

Instruction Manual

## WARRANTY:

The manufacturer warrants that this umbrella, when subject to normal and proper use, will be free from manufacturing defects for a period of one year from the original date of purchase. Should any defect occur during the specified time period, the manufacturer will repair, replace, or provide replacement parts, at its own option. Limited warranty against fabric fading, based on fabric grade. Warranty is not transferable.

We will not warrant any claim coverage unless both the original sales receipt and request form are sent to us. Any items that are returned for warranty or non warranty purposes must be issued a Return Authorization Number. Only

upon issuance of an RA # and inspection by our QC department will credit or replacement of umbrella be issued. It is the customer's responsibility to pay the freight on return products or replacement parts. ALL RETURNED ITEMS MUST INCLUDE THE RA# CLEARLY WRITTEN ON THE RETURN PACKAGE or package will be refused by our warehouse personnel.

NOTE: Damages and failure caused by improper use due to neglect of reasonable and necessary care are not covered by this warranty.

Additionally, acts of nature (including but not limited to wind, hurricanes, tornadoes, and storms) are not covered by this warranty.

## S A F E T Y P R E C A U T I O N S :

- Close the umbrella in windy conditions or when a storm approaches. Never allow the umbrella to flap in the wind; this could damage the canopy.
- Do not leave open umbrella unattended. If damage occurs, this is not covered by the warranty.
- When adjusting the umbrella, make sure that no person(s) or item(s) are close to the umbrella. This is important to prevent injury or material damage.

## C A R E A N D M A I N T E N A N C E :

- When not in use, close and cover umbrella with a protective cover (sold separately).
- Allow a wet canopy to dry opened up.
- If necessary, clean the fabric with lukewarm water, mild detergent, and a sponge.
- Wipe sliding marks on the aluminum poles with a damp cloth.











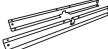





### Winter Storage:

- Store in a dry, protective place.
- Any visible defects must be repaired by a professional.

### After the Winter:

- Areas subject to turning and sliding can be treated with a non-staining lubricant spray (silicone-based).
- Check the condition and function of the umbrella. Any defects must be repaired by a professional.

## PART LIST

Part		Description	Qty.
①		Cross Bars	2
②		Main Frame with Canopy	1
③		Support Stem	1
④		Main Frame Support Tube	1
⑤		Gasket	1
⑥		Rotating Hub Cover	1
⑦		Rotating Hub	1
⑧		Foot Pedal	1
⑨		Knob	1
⑩		Crank Handle	1
⑪		Large Bolts	4
⑫		Medium Bolts	4
⑬		Small Screw	1
⑭		Washers	8
⑮		Wrench	1
⑯		Plug/Transformer/Cord	1

### REQUIRED FOR ASSEMBLY:

- One (1) Phillips Screwdriver
- Four (4) 40 lb. weights - square stones or concrete weights. (160 lb. total weight needed for support - **weights not included**) Stones & weights, standard sizes can be used up to 18" L x 18" W x 1.5" H.

**NOTE: Using the cross bar stand without weights will damage your umbrella and may cause injury.**

### STEP 7 Rotating Umbrella 360°

Place your foot on the foot pedal of the rotating hub and place hands on the main frame (Fig. 20). Swivel the umbrella frame in either direction until desired position is reached. There are 12 locking positions for the umbrella to rotate 360° (Fig. 21). Step off the foot pedal to engage rotating lock. Your umbrella will now be locked into desired location.

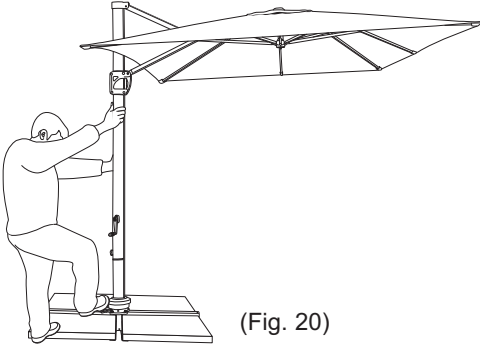

(Fig. 20)

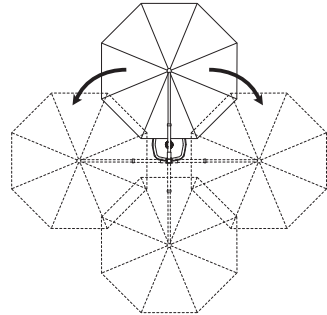

(Fig. 21)

### STEP 8 Closing Umbrella

To close umbrella, squeeze main frame grip handle (Fig. 22) and slide grip handle down to closed position (Fig. 23). Turn crank handle counter-clockwise (Fig. 24) until umbrella is closed (Fig. 25). Use ties to secure canopy to the main frame when umbrella is not in use.

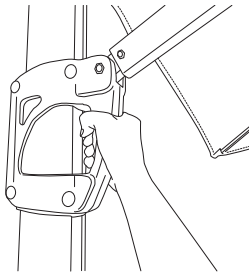

(Fig. 22)

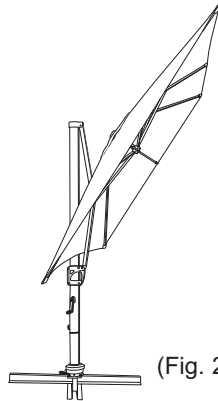

(Fig. 23)

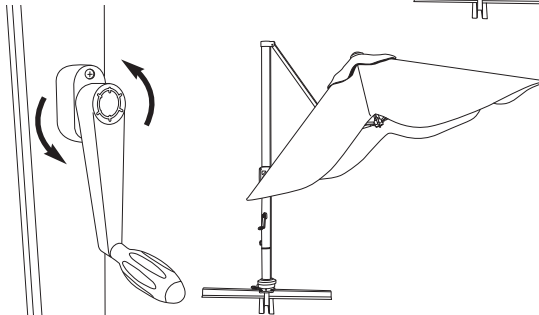

(Fig. 24)



(Fig. 25)

### STEP 3 Assemble Support Stem to Rotating Hub

Remove gasket and main frame support tube from support stem (Fig. 6) and set aside. Slide support stem over rotating hub (Fig. 7) and line up holes. Tighten with 4 supplied medium bolts and washers. Tighten with supplied wrench (Fig. 8). Slide rotating hub cover over rotating hub (Fig. 9).

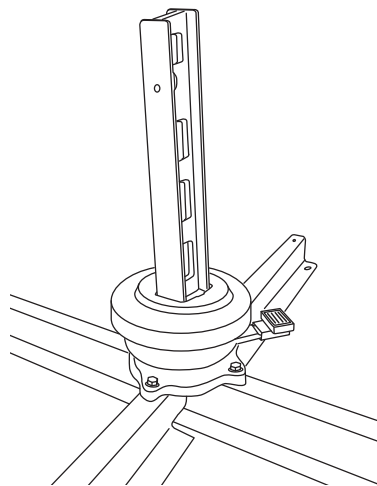
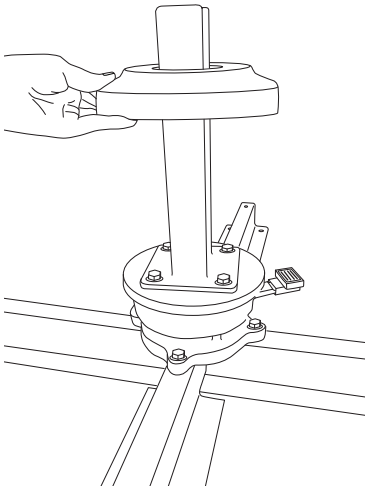
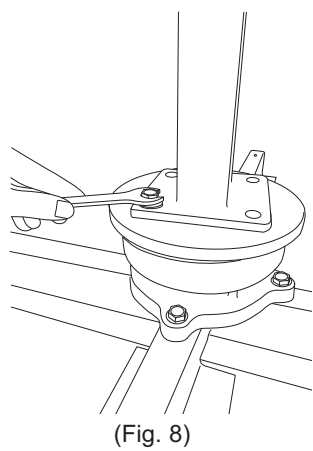
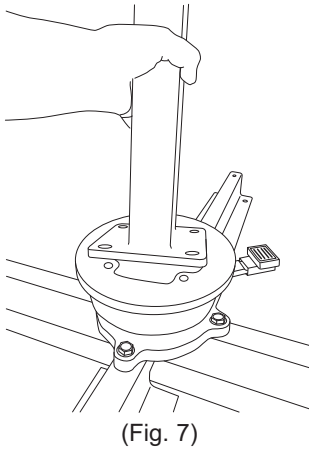
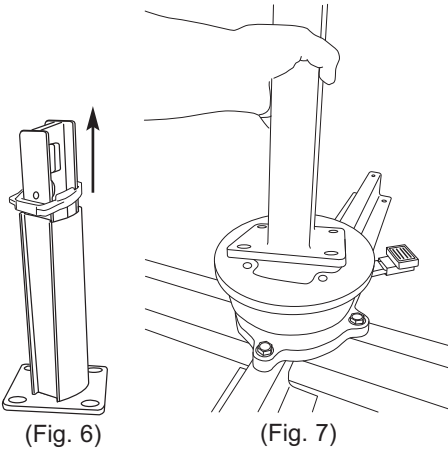

## STEP 5 Opening Umbrella

Attach crank handle to crank mechanism (Fig. 14). From closed position, turn the crank clockwise  (Fig. 15) until the umbrella is fully opened (Fig. 16) and the hub is at the top most position (Fig. 17). Tilt umbrella to desired position. See Step 6 for tilt operation.

**NOTE:** When cranking umbrella open, if you feel resistance and the umbrella is not opening, do not force the crank. Gently spread umbrella ribs with hands, then continue to crank open.

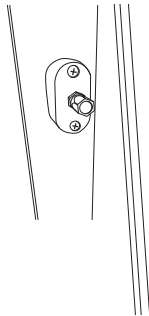

(Fig. 14)

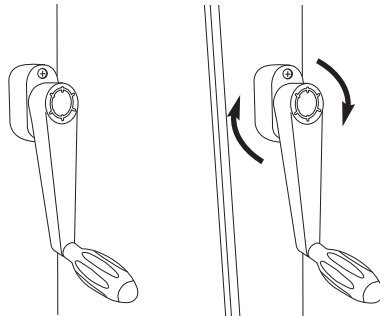

(Fig. 15)

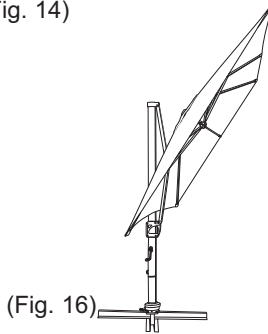

(Fig. 16)

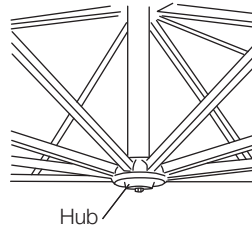

(Fig. 17)